

◆ Main Specifications

Heat-Resistant Class	Class E (120 °C)
Coil Saturation Temperature Rise $\Delta\theta_s$ (at 20 °C)	$\Delta\theta_s \doteq 18 \times W$ (°C) $K \doteq 18$ (°C/watt)
Temperature Rise Time Constant τ	7 (minutes)
Insulation Resistance	500V DC MEGA, 100M Ω or more
Dielectric Strength	1000V AC, 50/60Hz, 1 minute
Rotor Inertia	1.8 (g·cm ²)
Mass	70 (g)

◆ Coil Data

Duty Cycle	100%	50%	25%	10%	5%
	Continuous	Intermittent			
Max. ON Time [sec.]	∞	212.1	105.4	42.0	21.0
Power at 20 °C [W]	4.4	8.8	17.7	44.4	88.8
Resistance at 20 °C [Ω]	Voltage [V _{DC}]				
3.2	3.7	5.3	7.5	11.9	16.8
15.6 (standard)	8.2	11.7	16.6	26.3	37.2
60.0	16.2	22.9	32.5	51.6	72.9
125.0	23.4	33.1	47.0	74.4	105.3



◆ Torque Data

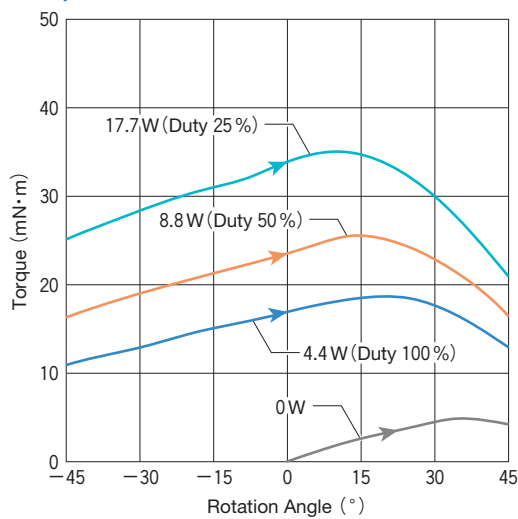

◆ Response Data

(Load Inertia : 3.97g·cm²)

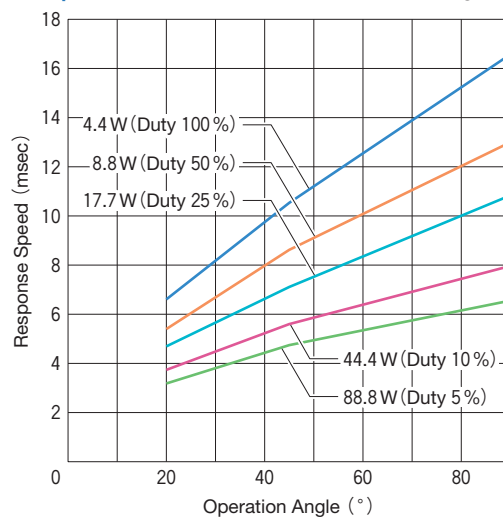

◆ External Dimensions (mm)

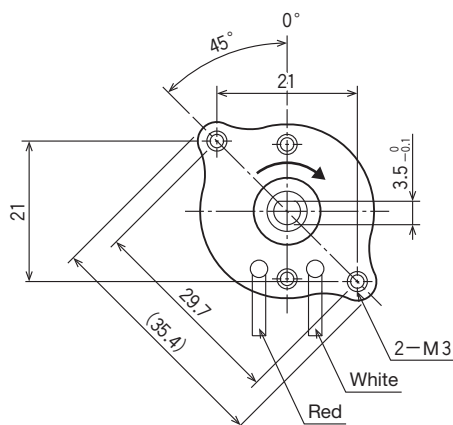

Terminal Specifications

Lead Wire Length (mm) : 300
AWG Size : 26

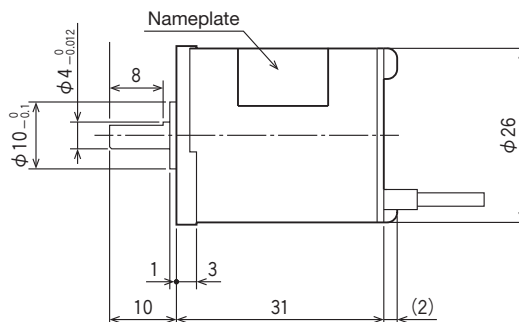

The above drawing shows the rotary shaft positioned in the center (0°) of its rotation range. When a positive electrode (+) is connected to the Red lead wire, and a negative electrode (-) to the White lead wire, the shaft rotates clockwise (in the direction shown by the arrow).