

Main Specifications

Heat-Resistant Class	Class E (120°C)
Coil Saturation Temperature Rise $\Delta\theta_s$ (at 20°C)	$\Delta\theta_s \doteq 20 \times W$ (°C) $K \doteq 20$ (°C/watt)
Temperature Rise Time Constant τ	5 (minutes)
Insulation Resistance	500V DC MEGA, 100 M Ω or more
Dielectric Strength	1000V AC, 50/60Hz, 1 minute
Rotor Inertia	1.3 (g·cm ²)
Mass	70 (g)

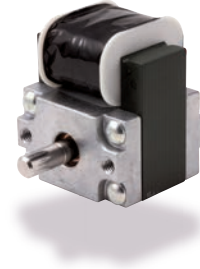

Coil Data

Duty Cycle	100%	50%	25%	10%	5%	
	Continuous	Intermittent				
Max. ON Time [sec.]	∞	150.0	75.0	30.0	15.0	
Power at 20°C [W]	4.0	8.0	16.0	40.0	80.0	
Resistance at 20°C [Ω]	Voltage [V _{DC}]					
	13.5	7.3	10.3	14.6	23.2	32.8
	60.0	15.4	21.9	30.9	48.9	69.2
	115.0 (standard)	21.4	30.3	42.8	67.8	95.9
	140.0	23.6	33.4	47.3	74.8	105.8

Torque Data

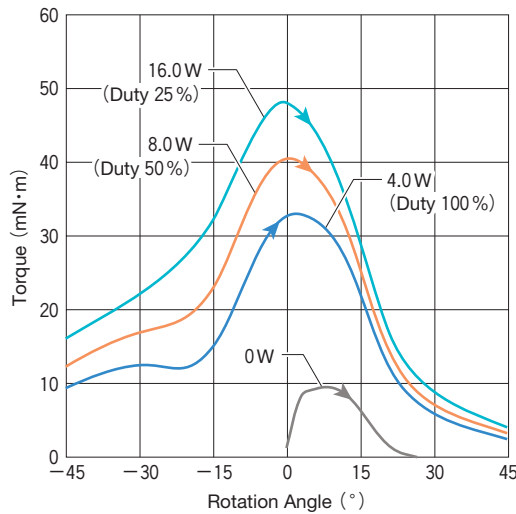

Response Data

(Load Inertia : 12.89 g·cm²)

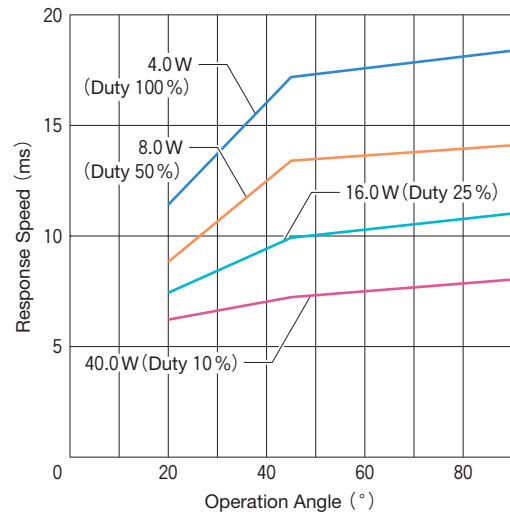

External Dimensions (mm)

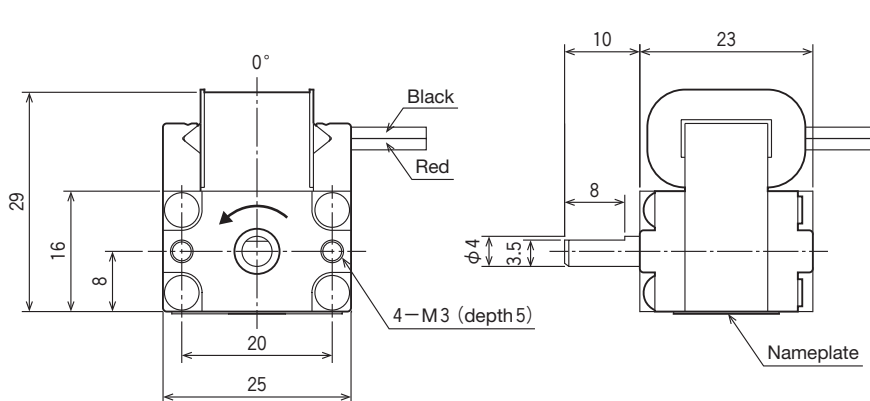

Terminal Specifications

Lead Wire Length (mm) : 200
AWG Size : 26

The above drawing shows the rotary shaft positioned in the center (0°) of its rotation range. When a positive electrode (+) is connected to the Red lead wire, and a negative electrode (-) to the Black lead wire, the shaft rotates counter clockwise (in the direction shown by the arrow).